

PART#	DIM "A"	APPROX. LBS
13128	9"	160LBS
13201	11 1/4"	165LBS

- Fire ring is constructed from 3/16" thick steel.
- Fire ring is formed (not welded) with a 1" flange fore superior strength.
- Grate is constructed from 1/2" dia. A36 steel bars located on 1 1/8" centers. The non-adjustable theft proof grate has a cooking area of 605 sq. inches.
- Grate handle is constructed of a 5/8" dia. A36 steel bar with stay cool spring grips suitable for public use.
- Ring is mounted using staples that allow the ring to tilt back for ease of cleaning optional spade anchors. The spade anchors permanently anchor the fire ring to the ground.
- All joints are continuously welded.
- All exposed corners are chamfered for safety.
- Standard finish is a non-toxic black powder coat.

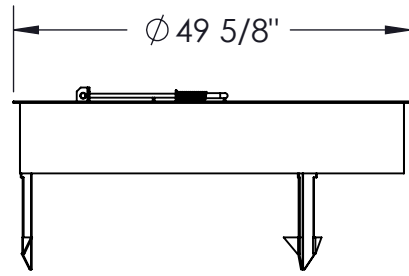

SPADE ANCHORS SHOWN

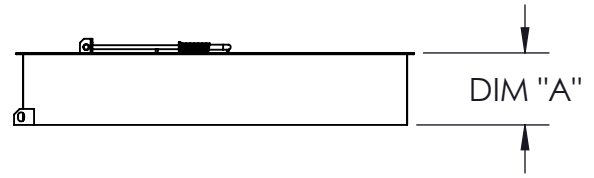

STAPLE MOUNTS SHOWN

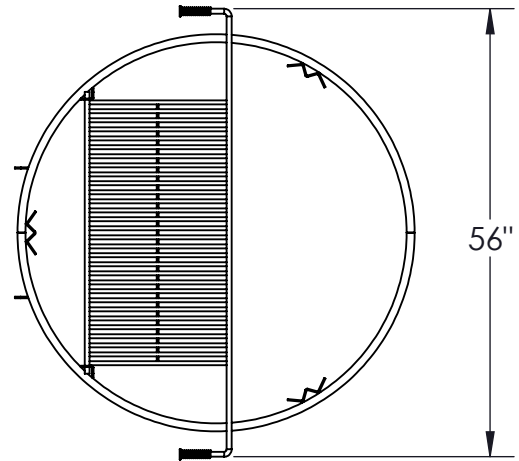
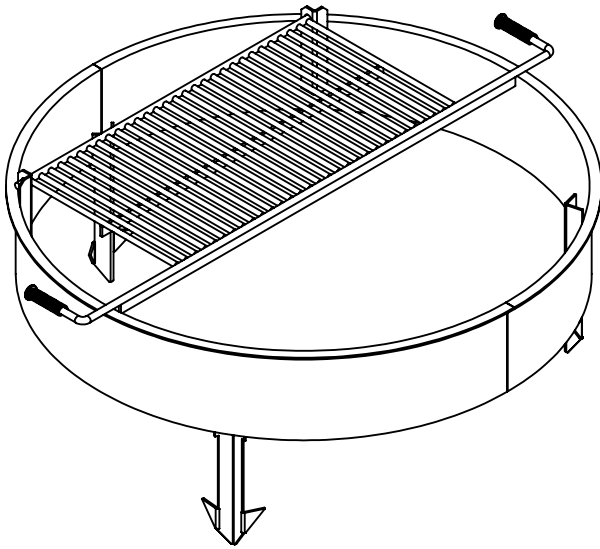

SPADE ANCHORS & STAPLE MOUNTS SHOWN

WARNING: MUST BE PERMANENTLY MOUNTED

CUSTOMER APPROVAL :

DATE :

JAMESTOWN
ADVANCED
PRODUCTS
CORPORATION

THIS DRAWING, WHICH CONTAINS PROPRIETARY INFORMATION, IS THE PROPERTY OF JAMESTOWN ADVANCED PRODUCTS CORPORATION. IT SHALL NOT BE REPRODUCED IN ANY MANNER NOR DISCLOSED TO THIRD PARTIES WITHOUT WRITTEN PERMISSION OF JAMESTOWN ADVANCED PRODUCTS CORPORATION.

DATE : 5/29/12

PRODUCT PART NUMBER : 13128 & 13201

REV. NO. 2 12/10/15

PRODUCT DESCRIPTION :

48" DIA. FIRE RING

2855 GIRTS ROAD
JAMESTOWN, NY 14701

PHONE 800-452-0639 -- FAX 716-483-5398 -- WWW.JAMESTOWNADVANCED.COM